

No	Nominal	Size	Fire Rating	Door				Frames				Fire Rating	Notes	
				Type	Material	Core	Finish	Glass	Hardware	Type	Material			Finish
D-005	6'-0"	7'-0"	45 min	A	HM	HC	PT	-	2	A	HM	PT	45 min	Storeroom level; LH leaf active; flush bolt for RH leaf
D-102A	3'-4"	7'-0"	45 min	B	HM	HC	PT	CE GL	3	A	HM	PT	45 min	Exit device c/w keyed cylinder, dogging and 5-pull; magnetic hold-open tied to FA system
D-102B	6'-0"	8'-0"	-	-	ALUM	-	-	TG	4	-	ALUM	-	-	Automatic sliding door with motion sensor operator; frame width = ±10'-0"; frame height = ±9'-0"; active door leaf nom. size = 3'-4" x 7'-4"; w/ breakout capacity; card reader access only when motion sensor is turned off; motion sensor activation to be manually controlled via keyswitch mounted adjacent to card reader
D-102C	10'-7"	9'-2"	-	-	ALUM	-	-	TG	4	-	ALUM	-	-	Sliding door with motion sensor operator; frame width = ±10'-7"; frame height = ±9'-2"; active door leaf nom. size = 4'-0" x 8'-6"; breakout capacity not required; card reader access only when motion sensor is turned off; motion sensor turned off and on manually via keyswitch mounted adjacent to card reader
D-103A	3'-3"	6'-8"	-	B	ALUM	-	-	TG	5	D	ALUM	-	-	Office lever; card reader + elec strike; full weatherstripping kit; corrosion-resistant hardware
D-103B	3'-3"	3'-10"	-	A	WD	SC	PLAM	-	6	-	WD	PLAM	-	Milwork swing door by milwork supplier
D-103C	3'-3"	7'-0"	-	B	HM	HC	PT	-	8	A	HM	PT	-	Office lever; card reader + elec strike
D-104	3'-3"	7'-0"	-	A	HM	HC	E-PT	-	7	A	HM	E-PT	-	Privacy lock; power door operator; push to lock button c/w indicator light on outside; emergency release mechanism (from exterior by authorized personnel)
D-105	3'-3"	7'-0"	-	A	GL	-	-	TG	9	-	-	-	-	Frameless glass door & sidelite; card reader + elec strike
D-106A	3'-3"	7'-10"	-	A	HM	HC	E-PT	-	7	A	HM	E-PT	-	Privacy lock; power door operator; push to lock button c/w indicator light on outside; emergency release mechanism (from exterior by authorized personnel)
D-106B	2'-6"	7'-10"	-	A	TFTN	SC	-	-	by supplier	-	TFTN	-	-	Toilet partition stall door
D-106C	2'-6"	7'-10"	-	A	TFTN	SC	-	-	by supplier	-	TFTN	-	-	Toilet partition stall door
D-107A	3'-3"	7'-10"	-	A	HM	HC	E-PT	-	7	A	HM	E-PT	-	Privacy lock; power door operator; push to lock button c/w indicator light on outside; emergency release mechanism (from exterior by authorized personnel)
D-107B	2'-6"	7'-10"	-	A	TFTN	SC	-	-	by supplier	-	TFTN	-	-	Toilet partition stall door
D-107C	2'-6"	7'-10"	-	A	TFTN	SC	-	-	by supplier	-	TFTN	-	-	Toilet partition stall door
D-110	3'-4"	7'-0"	45 min	A	HM	HC	PT	-	10	A	HM	PT	45 min	Classroom level
D-112A	4'-0"	7'-0"	-	A	WD	SC	PT	-	11	A	HM	PT	-	Storeroom level
D-112B	6'-0"	7'-0"	-	A	WD	SC	PT	-	12	A	HM	PT	-	Storeroom level; RH leaf active; flush bolt for LH leaf
D-115	4'-0"	7'-0"	45 min	A	HM	HC	PT	-	13	A	HM	PT	45 min	Storeroom level
D-116	3'-3"	7'-0"	-	A	HM	HC	PT	-	14	A	HM	PT	-	Passage lever
D-120	3'-4"	7'-0"	-	A	HM-INSUL	SC	PT	-	15	A	HM-INSUL	PT	-	Exit device (exit only); all hardware suitable for corrosive environment (pool) and high humidity; thermally broken frame & threshold; full high performance weatherstripping kit
D-123	3'-3"	7'-0"	-	A	HM	HC	PT	-	8	A	HM	PT	-	Office lever; card reader + elec strike
D-129A	± 3'-0"	± 7'-0"	-	B	ALUM	-	-	TG	9	A	ALUM	-	-	Office lever; card reader + elec strike
D-127	2'-8"	6'-10"	-	A	HM	HC	PT	-	16	A	HM	PT	-	Passage lever
D-128	2'-6"	2'-6"	-	A	HM	HC	PT	-	17	A	HM	PT	-	Access door to plumbing chase below WC 106/107; keyed cylinder at exterior; active lever trim @ interior (for egress)
D-129	2'-6"	2'-6"	-	A	HM	HC	PT	-	17	A	HM	PT	-	Access door to plumbing chase below WC 106/107; keyed cylinder at exterior; active lever trim @ interior (for egress)
D-131	3'-3"	7'-0"	-	A	HM	HC	E-PT	-	18	A	HM	E-PT	-	Privacy lever lock
D-200	6'-4"	6'-8"	45 min	A	HM-INSUL	SC	PT	-	19	B	HM-INSUL	PT	45 min	Entry level lock; LH leaf active; flush bolt for RH leaf; full weatherstripping kit
D-201	6'-4"	6'-8"	45 min	A	HM-INSUL	SC	PT	-	20	B	HM-INSUL	PT	45 min	Entry level lock; LH leaf active; flush bolt for RH leaf; full weatherstripping kit
D-202	3'-0"	7'-0"	45 min	A	HM	HC	PT	-	21	A	HM	PT	45 min	Passage lever
D-202A	3'-0"	7'-0"	-	A	HM	HC	PT	-	22	A	HM	PT	-	Passage lever
D-203	3'-3"	7'-0"	45 min	A	HM	HC	PT	-	21	A	HM	PT	45 min	Passage lever
XD-11A	± 3'-0"	± 7'-0"	45 min	-	X-HM	-	-	-	23	-	X-HM	PT	45 min	Retrofit exist. stairwell door for new card reader + electric strike;
XD-11B	± 3'-0"	± 7'-0"	45 min	-	X-HM	-	-	-	23	-	X-HM	PT	45 min	Retrofit exist. stairwell door for new card reader + electric strike;
XD-12	± 3'-0"	± 7'-0"	45 min	-	X-HM	-	-	-	23	-	X-HM	PT	45 min	Retrofit exist. stairwell door for new card reader + electric strike;
XD-100	± 6'-0"	± 7'-0"	-	-	X-ALUM	-	-	-	23	-	ALUM	PT	-	Retrofit exist. exterior double doors for new card reader + electric strike; allow for new electrified hinge and exit device to replace existing; provide latch monitor to interface with existing power door operator
XD-108	± 6'-0"	± 7'-0"	-	-	X-WD	-	-	-	23	-	X-WD	PT	-	Retrofit exist. interior double doors for new card reader + electric strike; allow for new electrified hinge and exit device to replace existing;
XD-125	± 3'-0"	± 7'-0"	-	-	X-HM	-	-	-	23	-	X-HM	PT	-	Retrofit exist. exterior door for new card reader + electric strike;
XD-127A	± 3'-0"	± 7'-0"	-	-	X-HM	-	-	-	23	-	X-HM	PT	-	Retrofit exist. exterior door for new card reader + electric strike; allow for new electrified hinge and exit device to replace existing; provide new D-style door pull at exterior
XD-127D	± 6'-0"	± 7'-0"	-	-	X-HM	-	-	-	23	-	X-HM	PT	-	Retrofit exist. interior double doors for new card reader + electric strike; allow for new electrified hinge and exit device to replace existing;
XD-EC	± 3'-0"	± 7'-0"	-	-	X-HM	-	-	-	23	-	X-HM	PT	-	Retrofit exist. exterior door for new card reader + electric strike; existing exit device and door pull to remain

### DOOR SCHEDULE GENERAL NOTES:

- DOOR HARDWARE SUPPLIER SHALL CAREFULLY SITE-REVIEW EXISTING DOORS THAT ARE TO BE RETRO-FITTED (AS NOTED ABOVE) AND PROVIDE REQUIRED HARDWARE TO SUIT DESIRED FUNCTIONALITY W/NEW CARD READER.
- UNLESS NOTED OTHERWISE, ALL EXIT DEVICES SHALL BE VON DUPRIN 9899 SERIES C/W TRIM FOR EXISTING DOORS THAT ARE BEING RETROFITTED (AS PER ABOVE) AND WHICH WILL REQUIRE NEW DEVICES.
- REMOVE EXISTING KNOB-SET LOCKS IN THE FOLLOWING ROOMS, AND REPLACE WITH SCHLAGE NO-SERIES PASSAGE SET LOCKSETS:  
-STORAGE RM 002 - STORAGE 004  
-EX. STORAGE 008 - EX. UTILITY 009  
-EX. MECH RM 010 - EX. JANITOR 011  
-EX. STAFF RM 013 - STAIR 012
- REMOVE EXISTING KNOB-SET LOCK ON EX. WASHROOM 012 AND REPLACE WITH SCHLAGE NO-SERIES PRIVACY LOCKSET.
- ALL HARDWARE IN POOL AREA INCL. CHANGE ROOMS/LIFEGUARD OFFICE/FIRST AID) SHALL BE SUITABLE FOR CORROSIVE ENVIRONMENT. ADJUST FINISHES TO SUIT.

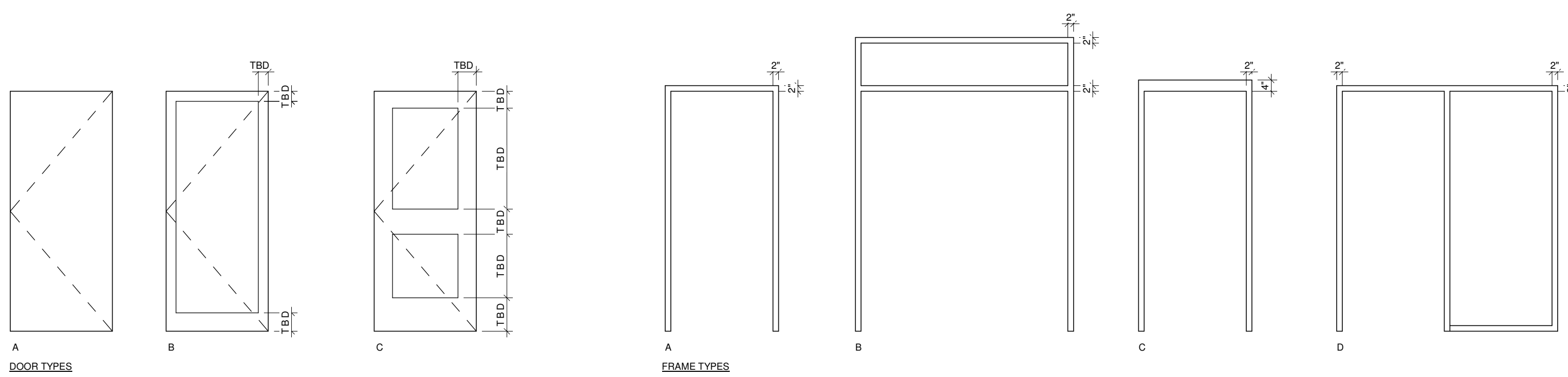

No Room Name	Floors		Walls								Ceiling		Notes
	Floor	Base	North		East		South		West		Material	Finish	
0.1 STAIR	X-COINC	-	X-CMU	PT	X-CMU	PT	X-CMU	PT	X-CMU	PT	-	-	repainting
0.2 STAIR	X-COINC	-	X-CMU	PT	X-CMU	PT	X-CMU	PT	X-CMU	PT	-	-	repainting
001 POOL EQUIPMENT	X-COINC	-	-	-	-	-	-	-	-	-	-	-	no finish work
1.1 STAIR	X-COINC	-	X-CMU	PT	X-CMU	PT	X-CMU	PT	X-CMU	PT	-	-	repainting
1.2 STAIR	X-COINC	-	X-CMU	PT	X-CMU	PT	X-CMU	PT	X-CMU	PT	-	-	repainting walls and infill ceiling slab
002 STORAGE ROOM	X-COINC	-	-	-	-	-	-	-	-	-	-	-	no finish work
003 ELECTRICAL ROOM	X-COINC	-	-	-	-	-	-	-	-	-	-	-	no finish work
004 STORAGE	X-COINC	-	X-COINC	-	X-CMU	PT	X-COINC	PT	-	-	-	-	finishes at new floor/walls only
004A CL.	X-COINC	-	X-COINC	-	X-CMU	PT	X-COINC	PT	X-CMU	-	EXP	-	finishes at new floor/walls only
005 UTILITY SPRINKLER	CONC-S	-	X-COINC	-	X-CMU	-	X-COINC	-	GWB	PT	X-COINC	-	finishes at new floor/walls only
006 LIFT	manuf	-	GWB	PT	GWB	PT	X-COINC/X-CMU	-	GWB/X-CMU	PT	X-MTL DK	PT	finishes at new floor/walls only
007 MACH. RM	CONC-S	RB	GWB	PT	X-CMU	PT	X-COINC	-	GWB	PT	EXP	-	no finish work
008 EX STORAGE	X-COINC	-	-	-	-	-	-	-	-	-	-	-	no finish work
009 EX. UTILITY	X-COINC	RB	-	-	-	-	-	-	-	-	-	-	no finish work
010 EX. MECHANICAL ROOM	X-COINC	-	-	-	-	-	-	-	-	-	-	-	no finish work
011 EX. JANITOR	X-COINC	-	-	-	-	-	-	-	-	-	-	-	no finish work
012 EX. WASHRM	X-COINC	-	-	-	-	-	-	-	-	-	-	-	no finish work
013 EX. STAFF ROOM	X-COINC	-	-	-	-	-	-	-	-	-	-	-	no finish work
100 VESTIBULE	X-TRZ	X-RB	X-SF/X-COINC	PT	X-COINC	PT	X-SF/X-COINC	PT	X-COINC	PT	X-COINC	PT	repainting; removal of existing ceiling soundproofing & ceiling repair
101 ENTRANCE	X-TRZ	X-RB	X-COINC	PT	X-COINC	PT	X-SF/X-COINC	PT	X-COINC	PT	X-COINC	PT	repainting; removal of existing ceiling soundproofing & ceiling repair
102 LOBBY	RAF	RB	X-CMU/CMU	PT	X-CMU/CMU/GLWB	PT	GWB	PT	X-CMU/GWB	PT	X-COINC/GWB	PT	existing concrete floor to be polished (light grind) and sealed
103 RECEPTION	RSF	RB	GWB	PT	GWB	PT	GWB	PT	X-CMU	PT	GWB/X-COINC	PT	no finish work
100A LIFEGUARD	RSF	RB	GWB	PT	X-CMU	PT	X-CMU	PT	X-COINC	PT	X-COINC	PT	no finish work
104 ULTR	X-COINC-P	RB	GWB	E-PT	X-CMU/GWB	E-PT	GWB	E-PT	GWB	E-PT	ACT-1	-	no finish work
105 OFFICE	RSF	RB	GWB	PT	X-CMU	PT	X-CMU/GL	PT	GWB/GL	PT	ACT-1	-	no finish work
106 UNIVERSAL WASHROOM	RAF	RB	X-CMU/CMU	E-PT	X-CMU/GWB	E-PT	CMU	E-PT	GWB	E-PT	X-MTL DK/GWB	E-PT	GWB above washroom stalls; exposed metal deck in open area
107 UNIVERSAL WASHROOM	RAF	RB	X-CMU/CMU	E-PT	GWB	E-PT	X-CMU/GWB	E-PT	X-CMU/GWB	E-PT	X-MTL DK/GWB	E-PT	GWB above washroom stalls; exposed metal deck in open area
108 AUDITORIUM	X-VCT	RB	X-CMU	PT	X-GWB	PT	X-PL	PT	X-CMU	PT	X-COINC	-	repainting all walls; existing ceiling soundproofing to remain
109 STAGE	X-CMU	PT	X-CMU	PT	X-CMU	PT	X-PL	PT	X-WD	PT	X-COINC	-	repainting all walls
110 CLASSROOM	RSF	RB	X-CMU	PT	X-CMU	PT	GWB	PT	X-CMU	PT	ACT-1	-	no finish work except existing ACT reinstall
111 EX. WOMENS W/C	-	-	-	-	-	-	-	-	-	-	-	-	no finish work except existing ACT reinstall
112 EX. MENS W/C	-	-	-	-	-	-	-	-	-	-	-	-	no finish work except existing ACT reinstall
112A STORAGE	X	RB	X-CMU/GWB	PT	X-CMU	PT	X-CMU	PT	X-CMU/CMU	PT	X-MTL DK	-	Existing exposed metal deck to remain
112B STORAGE	X	RB	GWB	PT	GWB	PT	X-CMU	PT	X-CMU	PT	X-MTL DK	-	Existing exposed metal deck to remain
113 EX. KITCHENETTE	-	-	-	-	-	-	-	-	-	-	-	-	no finish work except existing ACT reinstall
114 CORRIDOR	RSF	RB	X-CMU/GWB	PT	X-CMU/GWB	PT	X-CMU/GWB	PT	X-CMU	PT	X-MTL DK	PT	Existing exposed metal deck to remain and be repainted
114A EX. JAN. CL.	-	-	-	-	-	-	-	-	-	-	-	-	no finish work
115 JANITOR	RSF	CB	X-CMU	PT	X-CMU	PT	X-CMU/GWB	PT	GWB	PT	X-MTL DK	PT	Existing exposed metal deck to remain and be repainted
116 ANTE-ROOM	X-VCT	RB	GWB	PT	X-CMU	PT	X-CMU	PT	GWB	PT	X-MTL DK	PT	Existing exposed metal deck to remain and be repainted
117 DRESSING ROOM	-	-	-	-	-	-	-	-	-	-	-	-	no finish work
118 W/C	-	-	-	-	-	-	-	-	-	-	-	-	no finish work except existing ACT reinstall
119 LUNCH ROOM	-	-	-	-	-	-	-	-	-	-	-	-	no finish work except existing ACT reinstall
120 POOL AREA	-	-	-	-	-	-	-	-	-	-	-	-	no finish work except painting of M&E installations where exposed
120A VEST.	-	-	X-CMU	E-PT	X-CMU	E-PT	X-CMU	E-PT	X-CMU	E-PT	MTL DK	E-PT	High build epoxy paint system at new metal roof deck, existing OWS/J structure & exposed ME work. All existing CMU walls to be repainted
121 MENS LOCKER ROOM	X-CT	-	X-CMU	E-PT	X-CMU	E-PT	X-CMU	E-PT	X-CMU	E-PT	MTL DK	E-PT	High build epoxy paint system at new metal roof deck, existing OWS/J structure & exposed ME work. All existing CMU walls to be repainted
121A W/C	X-CT	-	X-CMU	E-PT	X-CMU	E-PT	X-CMU	E-PT	X-CMU	E-PT	MTL DK	E-PT	High build epoxy paint system at new metal roof deck, existing OWS/J structure & exposed ME work. All existing CMU walls to be repainted
121B SHOWER	X-CT	-	X-CMU	E-PT	X-CMU	E-PT	X-CMU	E-PT	X-CMU	E-PT	MTL DK	E-PT	High build epoxy paint system at new metal roof deck, existing OWS/J structure & exposed ME work. All existing CMU walls to be